

SMT Toroidal Coil Inductors GS68HC

Features (特長)

- Closed magnetic circuit for lowest EMI (閉合磁性電路防干擾對策)
- High Current. (高電流)

Applications (用途)

- Power switching, TV game, Monitor, Car recharger, etc.. (電源供應器、電視遊樂器、監視器、汽車充電器等)



Product Identification (產品識別)

GS68HC - ____ - ____ (Ex. GS68HC-52-100M)

1 2 3 4

1. SMD Toroidal Coil Inductors (SMD 環型線圈) (GS68HC)
2. Core Material (鐵芯材質)
3. Inductance (電感值)
4. Tolerance (誤差值) (參照表 K 10%, L 15%, M 20%, N 30%, Y min)

Configurations & Dimensions (結構圖及規格尺寸)

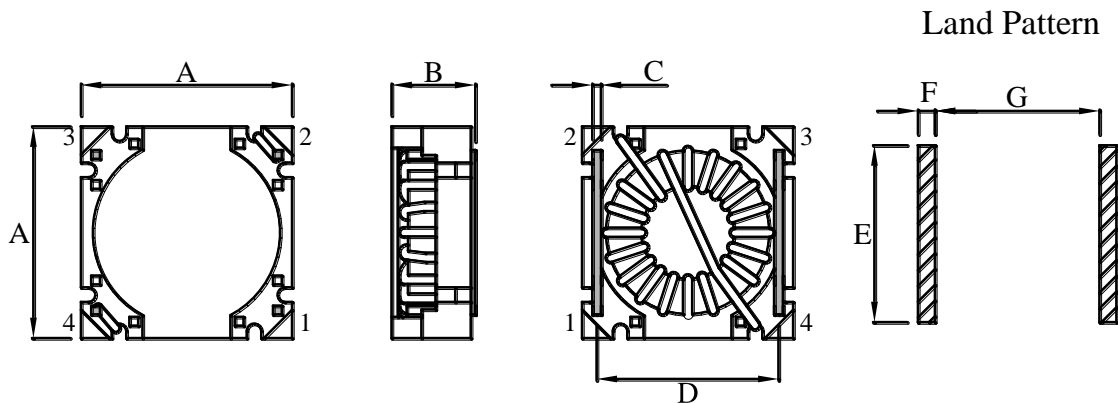

Unit In mm

Type (型式)	A	B	C	D	E	F	G
GS68HC	±0.5 24.0	±0.5 9.6	±0.2 1.0	±0.5 20.8	18.0	2.5	18.0

♣ Design as Customer's Requested Specifications. (可依客戶特殊需求設計)