

SMT Shielded Power Inductors

GSRH2D09A / GSRH2D11A / GSRH2D14A GSRH2D18A / GSRH3D11A / GSRH3D14ALD / GSRH3D14AHP GSRH3D16A GSRH3D28A / GSRH3D28ALD

Configurations & Dimensions (結構圖及規格尺寸)

GSRH2D09A / GSRH2D11A / GSRH2D14A / GSRH2D18A

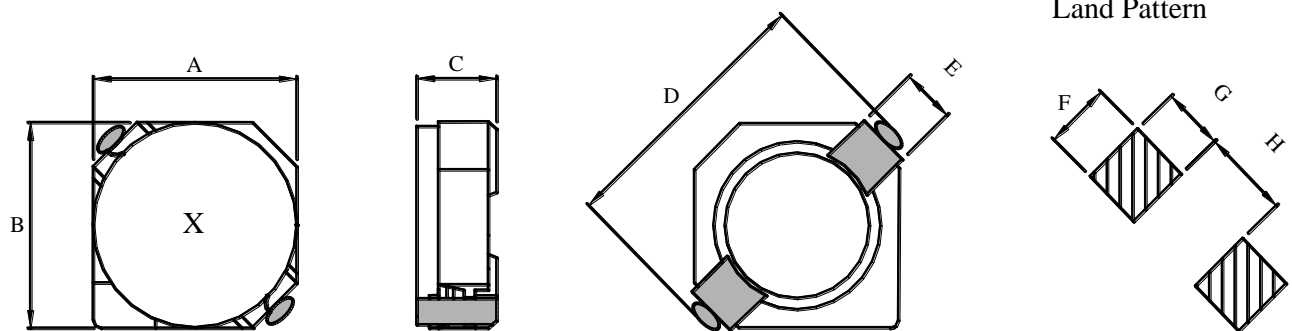

GSRH3D11A / GSRH3D14ALD / GSRH3D14AHP / GSRH3D16A / GSRH3D28A / GSRH3D28ALD

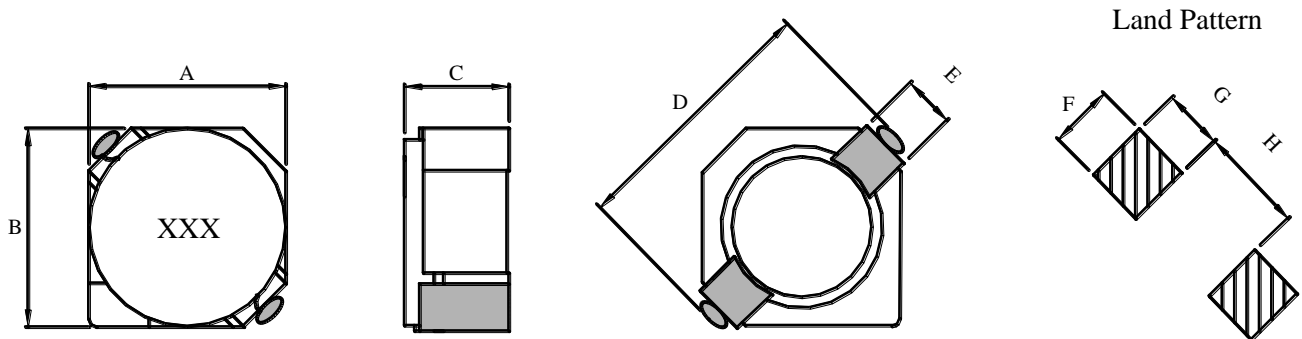

Unit In mm

Type (型式)	A (max)	B (max)	C (max)	D (max)	E (Ref.)	F	G	H
GSRH2D09A	3.2	3.2	1.00	4.3	1.0	1.3	1.3	1.7
GSRH2D11A	3.2	3.2	1.20	4.3	1.0	1.3	1.3	1.7
GSRH2D14A	3.2	3.2	1.55	4.3	1.0	1.3	1.3	1.7
GSRH2D18A	3.2	3.2	2.00	4.3	1.0	1.3	1.3	1.7
GSRH3D11A	4.0	4.0	1.2	5.2	1.0	1.3	1.4	2.4
GSRH3D14ALD/AHP	4.0	4.0	1.5	5.2	1.0	1.3	1.4	2.4
GSRH3D16A	4.0	4.0	1.8	5.2	1.0	1.3	1.4	2.4
GSRH3D28A/ALD	4.0	4.0	3.0	5.2	1.0	1.3	1.4	2.4

✦ Design as Customer's Requested Specifications. (可依客戶特殊需求設計)

SMT Shielded Power Inductors

GSRH2D09A

Electrical Characteristics for GSRH2D09A Series [GSRH2D09A 系列電子特性規格]

Part Number 產品料號	Marking 捺印	Inductance (μ H) 電感值 (L)	Test Freq. (KHz) 測試頻率	DCR (Ω) (max) 直流阻抗	Isat (A) (max) 定格電流	Irms (A) (max) 溫昇電流
GSRH2D09A - 1R2N	A	1.20	100	0.0975	0.80	1.24
GSRH2D09A - 1R5N	B	1.50	100	0.1100	0.73	1.15
GSRH2D09A - 1R8N	C	1.80	100	0.1310	0.65	1.06
GSRH2D09A - 2R2N	D	2.20	100	0.1440	0.60	1.05
GSRH2D09A - 2R5N	E	2.50	100	0.1500	0.53	0.98
GSRH2D09A - 3R0N	F	3.00	100	0.1940	0.47	0.84
GSRH2D09A - 3R9N	G	3.90	100	0.2250	0.45	0.72
GSRH2D09A - 4R7N	H	4.70	100	0.2880	0.41	0.64
GSRH2D09A - 5R6N	I	5.60	100	0.3250	0.37	0.59
GSRH2D09A - 6R8N	J	6.80	100	0.4250	0.33	0.53
GSRH2D09A - 8R2N	K	8.20	100	0.4750	0.30	0.46
GSRH2D09A - 100N	L	10.00	100	0.5380	0.28	0.42

※Test Freq. : 100KHz / 0.1V.

※Operating Temp. : $-40^{\circ}\text{C} \sim +125^{\circ}\text{C}$

※Inductance drop = 35% typ. at Isat.

※ $\Delta T=40^{\circ}\text{C}$ rise at Irms.

※Storage Temperature&Humidity : $\leq 40^{\circ}\text{C}$ & 70% RH maximum

GSRH2D11A

Electrical Characteristics for GSRH2D11A Series [GSRH2D11A 系列電子特性規格]

Part Number 產品料號	Marking 捺印	Inductance (μ H) 電感值 (L)	Test Freq. (KHz) 測試頻率	DCR (Ω) (max) 直流阻抗	Isat (A) (max) 定格電流	Irms (A) (max) 溫昇電流
GSRH2D11A - 1R5N	B	1.50	100	0.068	0.90	1.48
GSRH2D11A - 2R2N	D	2.20	100	0.098	0.78	1.27
GSRH2D11A - 3R3N	F	3.30	100	0.123	0.60	1.02
GSRH2D11A - 4R7N	H	4.70	100	0.170	0.50	0.88
GSRH2D11A - 6R8N	J	6.80	100	0.260	0.44	0.80
GSRH2D11A - 100N	L	10.00	100	0.400	0.35	0.65

※Test Freq. : 100KHz / 0.1V.

※Operating Temp. : $-40^{\circ}\text{C} \sim +125^{\circ}\text{C}$

※Inductance drop = 35% typ. at Isat.

※ $\Delta T=40^{\circ}\text{C}$ rise at Irms.

※Storage Temperature&Humidity : $\leq 40^{\circ}\text{C}$ & 70% RH maximum

SMT Shielded Power Inductors

GSRH2D14A

Electrical Characteristics for GSRH2D14A Series [GSRH2D14A 系列電子特性規格]

Part Number 產品料號	Marking 捺印	Inductance (μ H) 電感值 (L)	Test Freq. (KHz) 測試頻率	DCR (Ω) (max) 直流阻抗	Isat (A) (max) 定格電流	Irms (A) (max) 溫昇電流
GSRH2D14A - 1R5N	B	1.50	100	0.063	1.800	2.00
GSRH2D14A - 1R8N	C	1.80	100	0.075	1.650	1.80
GSRH2D14A - 2R2N	D	2.20	100	0.094	1.500	1.60
GSRH2D14A - 2R7N	E	2.70	100	0.106	1.350	1.40
GSRH2D14A - 3R3N	F	3.30	100	0.125	1.200	1.24
GSRH2D14A - 3R9N	G	3.90	100	0.138	1.100	1.12
GSRH2D14A - 4R7N	H	4.70	100	0.169	1.000	1.00
GSRH2D14A - 5R6N	I	5.60	100	0.188	0.945	0.98
GSRH2D14A - 6R8N	J	6.80	100	0.213	0.850	0.92
GSRH2D14A - 8R2N	K	8.20	100	0.281	0.800	0.80
GSRH2D14A - 100N	L	10.00	100	0.294	0.700	0.76
GSRH2D14A - 120N	M	12.00	100	0.394	0.620	0.64

※Test Freq. : 100KHz / 0.1V.

※Operating Temp. : $-40^{\circ}\text{C} \sim +125^{\circ}\text{C}$

※Inductance drop = 35% typ. at Isat.

※ $\Delta T=40^{\circ}\text{C}$ rise at Irms.

※Storage Temperature&Humidity : $\leq 40^{\circ}\text{C}$ & 70% RH maximum

GSRH2D18A

Electrical Characteristics for GSRH2D18A Series [GSRH2D18A 系列電子特性規格]

Part Number 產品料號	Marking 捺印	Inductance (μ H) 電感值 (L)	Test Freq. (KHz) 測試頻率	DCR (Ω) (max) 直流阻抗	IDC (A) (max) 定格電流
GSRH2D18A - 2R2N	C	2.20	100	0.043	0.85
GSRH2D18A - 3R3N	D	3.30	100	0.060	0.77
GSRH2D18A - 4R7N	F	4.70	100	0.081	0.63
GSRH2D18A - 6R8N	I	6.80	100	0.108	0.57
GSRH2D18A - 100N	K	10.00	100	0.201	0.45
GSRH2D18A - 150N	M	15.00	100	0.227	0.35
GSRH2D18A - 220N	O	22.00	100	0.331	0.30
GSRH2D18A - 330N	Q	33.00	100	0.481	0.23

※Test Freq. : 100KHz / 0.1V.

※Operating Temp. : $-40^{\circ}\text{C} \sim +125^{\circ}\text{C}$

※Inductance drop = 35% typ. at IDC.

※Storage Temperature&Humidity : $\leq 40^{\circ}\text{C}$ & 70% RH maximum

SMT Shielded Power Inductors

GSRH3D11A

Electrical Characteristics for GSRH3D11A Series [GSRH3D11A 系列電子特性規格]

Part Number 產品料號	Marking 捺印	Inductance (μ H) 電感值 (L)	Test Freq. (KHz) 測試頻率	DCR (Ω) (max) 直流阻抗	Isat (A) (max) 定格電流	Irms (A) (max) 溫昇電流
GSRH3D11A - 2R7N	U	2.70	100	0.078	0.53	1.82
GSRH3D11A - 4R7N	E	4.70	100	0.123	0.40	1.38
GSRH3D11A - 6R8N	F	6.80	100	0.180	0.34	1.05
GSRH3D11A - 8R2N	V	8.20	100	0.204	0.32	0.95
GSRH3D11A - 100M	G	10.00	100	0.240	0.28	0.90
GSRH3D11A - 120M	H	12.00	100	0.276	0.25	0.81
GSRH3D11A - 150M	I	15.00	100	0.372	0.23	0.68
GSRH3D11A - 180M	J	18.00	100	0.468	0.21	0.58
GSRH3D11A - 220M	K	22.00	100	0.540	0.19	0.53
GSRH3D11A - 270M	L	27.00	100	0.726	0.17	0.48
GSRH3D11A - 330M	M	33.00	100	0.822	0.15	0.41
GSRH3D11A - 390M	N	39.00	100	0.942	0.14	0.40

※Test Freq. : 100KHz / 0.1V.

※Operating Temp. : $-40^{\circ}\text{C} \sim +125^{\circ}\text{C}$

※Inductance drop = 35% typ. at Isat.

※ $\Delta T=40^{\circ}\text{C}$ rise at Irms.

※Storage Temperature&Humidity : $\leq 40^{\circ}\text{C}$ & 70% RH maximum

SMT Shielded Power Inductors

GSRH3D14ALD

Electrical Characteristics for GSRH3D14ALD Series [GSRH3D14ALD 系列電子特性規格]

Part Number 產品料號	Marking 捺印	Inductance (μ H) 電感值 (L)	Test Freq. (KHz) 測試頻率	DCR (Ω) (max) 直流阻抗	Isat (A) (max) 定格電流	Irms (A) (max) 溫昇電流
GSRH3D14ALD - 1R2N	LA	1.20	100	0.038	1.500	2.70
GSRH3D14ALD - 1R5N	LB	1.50	100	0.048	1.350	2.40
GSRH3D14ALD - 2R2N	LC	2.20	100	0.055	1.150	2.20
GSRH3D14ALD - 2R7N	LD	2.70	100	0.068	1.050	1.90
GSRH3D14ALD - 3R3N	LE	3.30	100	0.077	0.950	1.60
GSRH3D14ALD - 3R9N	LF	3.90	100	0.096	0.800	1.50
GSRH3D14ALD - 4R7N	LG	4.70	100	0.105	0.750	1.45
GSRH3D14ALD - 5R6N	LH	5.60	100	0.159	0.700	1.10
GSRH3D14ALD - 6R8N	LI	6.80	100	0.173	0.600	1.05
GSRH3D14ALD - 8R2N	LJ	8.20	100	0.175	0.520	1.00
GSRH3D14ALD - 100M	LK	10.00	100	0.220	0.500	1.00
GSRH3D14ALD - 120M	LL	12.00	100	0.270	0.450	0.80
GSRH3D14ALD - 150M	LM	15.00	100	0.302	0.400	0.75
GSRH3D14ALD - 220M	LO	22.00	100	0.447	0.350	0.60
GSRH3D14ALD - 330M	LQ	33.00	100	0.848	0.300	0.40
GSRH3D14ALD - 470M	LS	47.00	100	1.080	0.250	0.35

※Test Freq. : 100KHz / 0.1V.

※Operating Temp. : $-40^{\circ}\text{C} \sim +125^{\circ}\text{C}$

※Inductance drop = 35% typ. at Isat.

※ $\Delta T=40^{\circ}\text{C}$ rise at Irms.

※Storage Temperature&Humidity : $\leq 40^{\circ}\text{C}$ & 70% RH maximum

SMT Shielded Power Inductors

GSRH3D14AHP

Electrical Characteristics for GSRH3D14AHP Series [GSRH3D14AHP 系列電子特性規格]

Part Number 產品料號	Marking 捺印	Inductance (μ H) 電感值(L)	Test Freq. (KHz) 測試頻率	DCR (Ω) (max) 直流阻抗	Isat (A) (max) 定格電流	Irms (A) (max) 溫昇電流
GSRH3D14AHP - 1R5N	HB	1.5	100	0.076	2.60	1.85
GSRH3D14AHP - 2R4N	HC	2.4	100	0.129	2.00	1.32
GSRH3D14AHP - 3R2N	HE	3.2	100	0.139	1.80	1.25
GSRH3D14AHP - 4R7N	HG	4.7	100	0.214	1.45	1.04
GSRH3D14AHP - 6R8N	HH	6.8	100	0.290	1.20	0.84
GSRH3D14AHP - 100M	HJ	10.0	100	0.440	1.00	0.67
GSRH3D14AHP - 150M	HL	15.0	100	0.650	0.80	0.50
GSRH3D14AHP - 220M	HN	22.0	100	0.830	0.65	0.48

※Test Freq. : 100KHz / 0.1V.

※Operating Temp. : $-40^{\circ}\text{C} \sim +125^{\circ}\text{C}$

※Inductance drop = 35% typ. at Isat.

※ $\Delta T=40^{\circ}\text{C}$ rise at Irms.

※Storage Temperature&Humidity : $\leq 40^{\circ}\text{C}$ & 70% RH maximum

GSRH3D16A

Electrical Characteristics for GSRH3D16A Series [GSRH3D16A 系列電子特性規格]

Part Number 產品料號	Marking 捺印	Inductance (μ H) 電感值(L)	Test Freq. (KHz) 測試頻率	DCR (Ω) (max) 直流阻抗	IDC (A) (max) 定格電流
GSRH3D16A - 1R5N	1R5	1.50	100	0.052	1.55
GSRH3D16A - 2R2N	2R2	2.20	100	0.072	1.20
GSRH3D16A - 3R3N	3R3	3.30	100	0.085	1.10
GSRH3D16A - 4R7N	4R7	4.70	100	0.105	0.90
GSRH3D16A - 6R8N	6R8	6.80	100	0.170	0.73
GSRH3D16A - 100N	100	10.00	100	0.210	0.55
GSRH3D16A - 150N	150	15.00	100	0.295	0.45
GSRH3D16A - 220N	220	22.00	100	0.430	0.40
GSRH3D16A - 330N	330	33.00	100	0.675	0.32

※Test Freq. : 100KHz / 0.1V.

※Operating Temp. : $-40^{\circ}\text{C} \sim +125^{\circ}\text{C}$

※Inductance drop = 35% typ. at IDC.

※Storage Temperature&Humidity : $\leq 40^{\circ}\text{C}$ & 70% RH maximum

SMT Shielded Power Inductors

GSRH3D28A

Electrical Characteristics for GSRH3D28A Series [GSRH3D28A 系列電子特性規格]

Part Number 產品料號	Marking 捺印	Inductance (μ H) 電感值 (L)	Test Freq. (KHz) 測試頻率	DCR (Ω) (max) 直流阻抗	Isat (A) (max) 定格電流	Irms (A) (max) 溫昇電流
GSRH3D28A - 3R3N	D	3.30	100	0.0721	2.00	1.85
GSRH3D28A - 4R7N	E	4.70	100	0.0883	1.65	1.62
GSRH3D28A - 6R8N	F	6.80	100	0.1190	1.24	1.32
GSRH3D28A - 100M	G	10.00	100	0.1450	1.05	1.18
GSRH3D28A - 150M	I	15.00	100	0.2130	0.90	1.02
GSRH3D28A - 220M	K	22.00	100	0.3350	0.76	0.74
GSRH3D28A - 330M	M	33.00	100	0.4810	0.58	0.63
GSRH3D28A - 470M	O	47.00	100	0.5990	0.48	0.56

※Test Freq. : 100KHz / 0.1V.

※Operating Temp. : $-40^{\circ}\text{C} \sim +125^{\circ}\text{C}$

※Inductance drop = 35% typ. at Isat.

※ $\Delta T=40^{\circ}\text{C}$ rise at Irms.

※Storage Temperature&Humidity : $\leq 40^{\circ}\text{C}$ & 70% RH maximum

SMT Shielded Power Inductors

GSRH3D28ALD

Electrical Characteristics for GSRH3D28ALD Series [GSRH3D28ALD 系列電子特性規格]

Part Number 產品料號	Marking 捺印	Inductance (μ H) 電感值 (L)	Test Freq. (KHz) 測試頻率	DCR (Ω) (max) 直流阻抗	Isat (A) (max) 定格電流	Irms (A) (max) 溫昇電流
GSRH3D28ALD - 100M	LG	10.00	100	0.095	0.50	1.52
GSRH3D28ALD - 120M	LH	12.00	100	0.100	0.45	1.48
GSRH3D28ALD - 150M	LI	15.00	100	0.115	0.40	1.44
GSRH3D28ALD - 180M	LJ	18.00	100	0.125	0.35	1.37
GSRH3D28ALD - 220M	LK	22.00	100	0.145	0.33	1.28
GSRH3D28ALD - 270M	LL	27.00	100	0.175	0.29	1.18
GSRH3D28ALD - 330M	LM	33.00	100	0.215	0.28	1.15
GSRH3D28ALD - 390M	LN	39.00	100	0.225	0.25	1.00
GSRH3D28ALD - 470M	LO	47.00	100	0.305	0.23	0.81
GSRH3D28ALD - 560M	LP	56.00	100	0.325	0.20	0.76
GSRH3D28ALD - 680M	LQ	68.00	100	0.470	0.185	0.60
GSRH3D28ALD - 820M	LR	82.00	100	0.540	0.172	0.58
GSRH3D28ALD - 101M	LS	100.00	100	0.610	0.160	0.52
GSRH3D28ALD - 121M	LT	120.00	100	0.755	0.136	0.50
GSRH3D28ALD - 151M	LU	150.00	100	0.880	0.124	0.48
GSRH3D28ALD - 181M	LV	180.00	100	1.130	0.119	0.42
GSRH3D28ALD - 221M	LW	220.00	100	1.270	0.116	0.36

※Test Freq. : 100KHz / 0.1V.

※Operating Temp. : $-40^{\circ}\text{C} \sim +125^{\circ}\text{C}$

※Inductance drop = 35% typ. at Isat.

※ $\Delta T=40^{\circ}\text{C}$ rise at I rms.

※Storage Temperature&Humidity : $\leq 40^{\circ}\text{C}$ & 70% RH maximum